



DOWNTOWN SOUTH BEND LIGHT POLE BANNER DISPLAY PROGRAM

About

Downtown South Bend, Inc. has launched a Light Pole Banner Program that allows area organizations to display banners on the new light poles installed along Michigan Street (Colfax Ave. to Wayne St.) and Jefferson Blvd (Michigan St. to St. Joseph). The goal of this program is to increase awareness of downtown events, activities and organizations as well as add color and excitement to the downtown streetscape.

Who's Eligible

The banner program is open to area non-profit organizations. Eligible banners are those that match the above stated goals of the Banner Program. Banners may not advertise or promote commercial products or services, or religious, political or social viewpoints. Applicant's name or logo may occupy no more than the lower 15% of the banner.

Application Process

- A completed banner application (Exhibit A) must be submitted to DTSB at least 45 days before the display period. The application must include a full color design of the banner artwork – front and back
- Once the application is received, DTSB staff will review the design and schedule of the banners to be displayed.
- DTSB staff will contact the applicant within two weeks of receiving the application and inform them of their decision. Banner approval is based upon adherence to program guidelines in accordance with requirements established by City of South Bend, Indiana and the Board of Public Works (BPW).
- Upon approval, a Banner Use agreement (Exhibit B) will be issued to the applicant.
- Applicant may then begin fabricating the banners. **Note: Applicant is responsible for all costs associated with production of the banners.**



Banner produced by the South Bend Museum of Art as part of the DTSB pilot program for light pole banners.

Quantity

New light poles have been installed along Michigan Street from Colfax Ave. to Wayne St. as well as on Jefferson St. The poles are owned by the City of South Bend.

- Number of poles available on **Michigan Street - 25**
 - Minimum Banner Quantity: 10; Maximum Quantity: 25
- Number of poles available on **Jefferson Street - 11**
 - Minimum Banner Quantity: 11

Specifications

Size: Length x Width ratio- 51" x 24"

Material: Banners should be made of at least 15oz. rip-stop type vinyl that is weather resistant. Two double stitched 2.75" banner arm pockets must be included at top and bottom of banner.

Number of Sides: Banners must be two sided.

Delivery

Banners must be delivered 5 business days prior to targeted installation date. Banners must be picked-up within 7 business days at conclusion of banner display period. DTSB will not store banners.

Display Time

Banners will be displayed for a minimum of 30 days and a maximum of 90 days. Extensions to the display period can be given if the applicant submits a written request to DTSB stating the reasons for the extension. Scheduling of the banners will be done on a first come basis.

Installation Fees

Banners will be installed by DTSB Ambassadors. There are no installation fees at this time.

Disclaimer

Downtown South Bend, Inc. reserves the right to revise or amend the guidelines of the Light Pole Banner Display program at any time. Additional fees or charges may be added if deemed necessary.

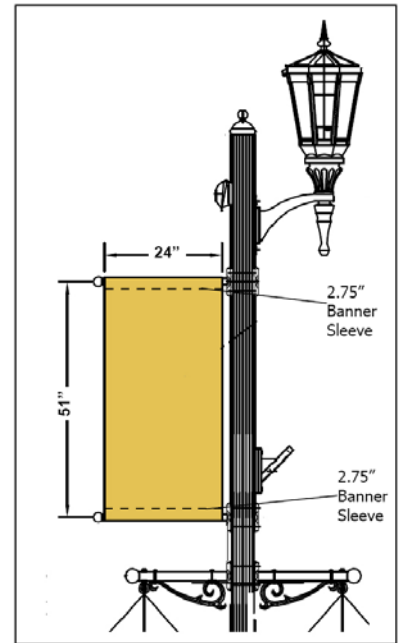

DOWNTOWN SOUTH BEND
LIGHT POLE BANNER PROGRAM
APPLICATION

Exhibit A

Applicant's Name: _____

Organization/Business: _____

Contact Address: _____

City/State/Zip: _____

Applicant's Phone (daytime): _____ Fax: _____

Applicant's Email: _____

Event Name: _____

Briefly describe the event: _____

Event Date(s) From: _____ To: _____

Banner display dates From: _____ To: _____
(minimum of 30 days)

Note: Attach a full color version of the banner design (front & back) with this application. You can attach a hard copy of the design or email a pdf or jpeg to jkain@downtownsouthbend.com

I have reviewed this application and understand the Banner Display Program requirements and agree to the terms and conditions of the program as stated.

Signature

Date

Mail completed applications to:

DTSB
c/o Light Pole Banner Program
PO Box 930
South Bend, IN 46624
Fax: 574.233.7382

For Office Use



Date Received: _____ Approved by: _____